

bj·gear



Designed for
Linear motion
Worm gear screw jacks

Customisation is our standard

Strong position through flexible solutions

BJ-Gear A/S is a leading company within developing, manufacturing and assembling of gearboxes, actuators, worm gear screw jacks, brakes and electromechanical cylinders.

We produce a wide range of standard gearboxes and actuators and e.g supply motors, encoders, electro-magnetic brakes and couplings of recognised manufacturers, making it possible to supply complete transmission solutions at short notice.

The flexible production machinery, along with our modular designed product range allow very short and precise delivery times.

BJ-Gear A/S supplies reliable transmission solutions for industries such as healthcare, food processing and packaging, aerospace and defense, offshore and marine, the energy and environment sector and to many other business areas.

The combination of innovation, know-how, high-technological production facilities and our focus on customer requirements makes us a competent partner.

Customisation is our standard

Worm gear screw jacks convert a rotary motion into a linear motion. BJ-Gear A/S supply worm gear screw jacks in four versions: with rotating trapezoidal spindle, with stagnant trapezoidal spindle and rotating nut, with rotating ball screw and with stagnant ball spindle and rotating nut.

BJ worm gear screw jacks are very sturdy in terms of overload and operating environment. The design is compact, simple and its modular construction allows great flexibility. The modular design is also ideal if customisations are needed.

If higher speed and loads are needed, we have extensive experience in adapting or designing special solutions.

We are certified according to EN ISO 9001 and EN ISO 14001.

Worm gear screw jacks

Worm gear screw jacks with trapezoidal spindle

Worm gear screw jacks with trapezoidal spindle are primarily used when relatively slow axial speed is needed and/or when the compact design of the worm gearbox is of advantage. A standard worm gear screw jack with trapezoidal spindle ensures a tensile and compression force of up to 40,000 N and a linear speed of up to 2,800 mm/min.

Worm gear screw jacks with ball screw spindle

A worm gear screw jack with ball screw spindle provides advantages over the trapezoidal spindle in relation to efficiency, speed, precision and running time.

By using a standard worm gear screw jack with ball screw spindle, you can achieve a linear speed of up to 25,000 mm/min. Since the ball screw has a very high efficiency, it will limit the accumulation of heat in the spindle and nut. That makes the ball screw suitable for continuous operation.



**Worm gear screw jacks
with trapezoidal spindle**



**Worm gear screw jacks
with ball screw spindle**

Worm gear screw jacks

with trapezoidal spindle

BJ-Gear A/S offers four types of worm gear screw jacks. We have two types with trapezoidal spindle and two types with ball screw spindle.

Our worm gear screw jack with through-going trapezoidal spindle is the focus in this catalogue.

Through-going spindle

The spindle moves axially through the gearbox without rotation*.

The nut is integrated into the gearbox.

Oil seal ring with dust lip

Integrated bronze nut

End cover ND-side

Tapered roller bearings

Worm wheel

Oil seal ring

Worm

Cast iron housing

Motor flange

Thread

Side flange / bearing cover

Trapezoidal spindle

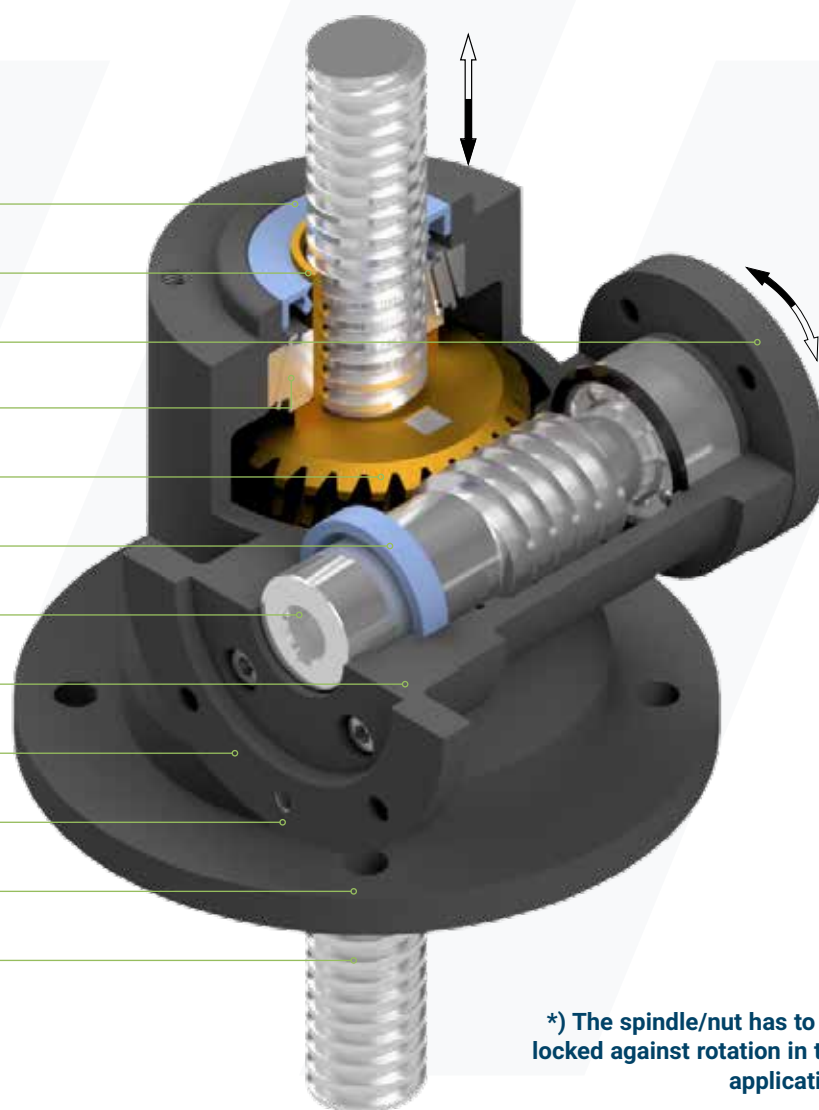

*) The spindle/nut has to be locked against rotation in the application

Trapezoidal, rotating spindle

The spindle is fastened to the hollow shaft of the gearbox and rotates. The nut moves axially to the spindle*.

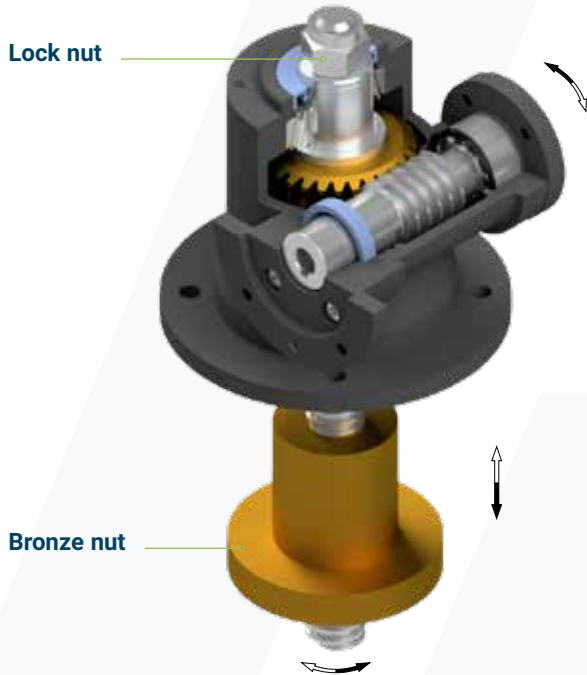

Configuring BJ-Gear's worm gear screw jacks with rotating trapezoidal spindle and with ball screw spindle requires contact to the BJ-Gear Sales Department.

Rotating ball screw spindle

The spindle is fastened to the hollow shaft of the gearbox and rotates. The nut moves axially to the spindle*.

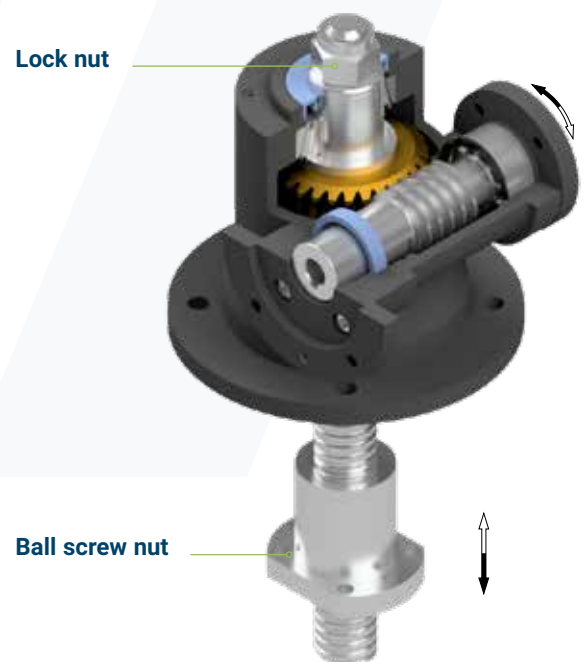

Through-going ball screw spindle

The spindle moves axially through the gearbox without rotation*. The nut is integrated into the gearbox.

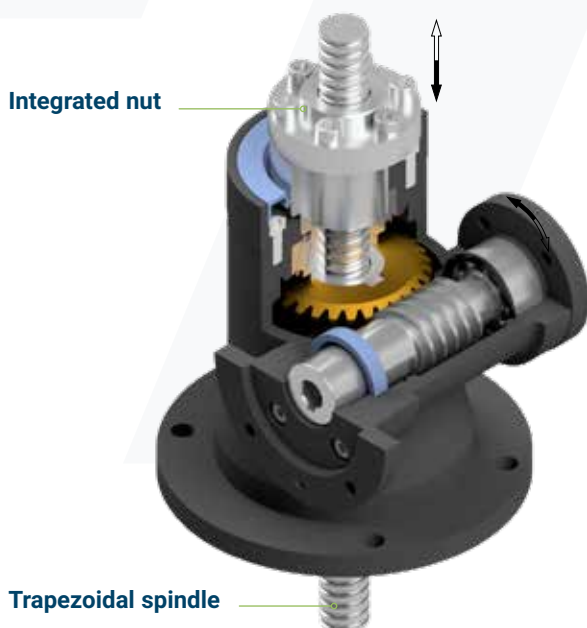

Type designation

2 52 1 0 72 2 13 03 01 40 0 0

We believe that an unambiguous type designation of our worm gear screw jacks eases the communication. Therefore, throughout this brochure the position of each item in the type designation will be shown. The number 2 designates that it is a worm gear screw jack.

2 52 1 0 72 2 13 03 01 40 0 0

Size of worm gear screw jacks

The worm gear screw jacks are as standard made in four sizes with housings of cast iron. The individual sizes are numbered according to the centre distances between worm and worm wheel. A gearbox with a centre distance of 52.5 is designated Series 52 and is assigned number 52 on position no. 2 in the type designation.

Please be aware that any uncontrolled stops must be prevented, i.e. running against mechanical stop or gear housing must not occur.

Shaft	TR24x5	TR30x6	TR40x7	TR40x7
Series	42	52	61	79

Duty factor

All data are based on the duty factor = 1.0 meaning that the duty factor of the worm gear screw jacks should not exceed ED 20 % per hour and maximum ED 40 % per 10 minutes. If the ED is more than 50 %, consider using a ball screw spindle instead, since it has higher duty cycles and can meet demands up to ED 100 %.



For other duty factors choose the values from this table (calculation example can be found on page 16):

ED % per hour	20	30	40	50	60	70	80	90	100
Load factor trapezoidal spindle	1,0	0,7	0,6	0,5	*	*	*	*	*

* Are you considering using a ball screw spindle, please contact BJ-Gear A/S

Tables of effects

For worm gear screw jacks with through-going spindle, ED 20 %

Motor		Series 42											
		η start [%]	19	18	17	15	13	12	10	8	7	6	5
		Gear ratio	5,4:1	7,5:1	10:1	15:1	20:1	25:1	30:1	40:1	50:1	62:1	75:1
[rpm]	[kW]	v [mm/min]	648	467	350	233	175	140	117	88	70	56	47
		maximum pull/thrust load with spindle TR 24x5 [kN]											
700	0,09		2,0	2,6	3,2	3,9	5,0	6,0	6,3	6,9	7,6	8,0	9,0
	0,12		2,8	3,7	4,2	5,6	6,6	8,1	8,4	9,5	10,3	11,0	12,1
	0,18*		4,4	5,5	6,7	8,5	10,4	12,4	12,9	14,7	15,8	16,5	
	0,25*		6,0	8,0	9,1	12,1	14,5	17,2	18,3				
	0,37*		9,2	12,5	14,1								
[rpm]	[kW]	v [mm/min]	833	600	450	300	225	180	150	113	90	73	60
		maximum pull/thrust load with spindle TR 24x5 [kN]											
900	0,09					3,4	3,6	4,7	4,8	5,7	6,4	6,8	7,5
	0,12		2,3	2,9	3,5	4,6	5,3	6,6	7,2	8,1	8,8	9,5	10,3
	0,18		3,6	4,3	5,7	7,6	8,2	10,1	10,9	12,4	13,8	14,7	
	0,25		4,9	6,2	8,2	10,6	11,6	14,4	15,4	17,6	19,0		
	0,37*		7,5	9,3	12,1	16,0							
	0,55*		11,2										
[rpm]	[kW]	v [mm/min]	1,296	933	700	467	350	280	233	175	140	113	93
		maximum pull/thrust load with spindle TR 24x5 [kN]											
1400	0,09				1,6	2,0	2,6	3,1	3,3	4,0	4,3	4,7	5,3
	0,12		1,4	1,8	2,3	2,9	3,6	4,4	4,7	5,2	6,1	6,6	7,4
	0,18		2,3	2,9	3,5	4,2	5,6	6,6	7,2	8,1	9,5	10,2	11,3
	0,25		3,2	4,0	4,7	6,2	7,8	9,4	10,4	11,6	13,6	14,6	
	0,37		4,6	6,0	7,3	9,5	12,0	14,1	15,7	17,1	19,9		
	0,55*		7,0	9,2	11,3	14,3							
	0,75*		9,9										
[rpm]	[kW]	v [mm/min]	2,593	1,867	1,400	933	700	560	467	350	280	226	187
		maximum pull/thrust load with spindle TR 24x5 [kN]											
2800	0,18		1,1	1,4	1,7	2,4	3,1	3,7	4,1	4,4	5,1	5,8	6,4
	0,25		1,6	2,1	2,6	3,7	4,2	5,1	5,8	6,9	7,5	8,4	9,1
	0,37		2,5	3,3	3,9	5,3	6,9	7,8	8,8	10,5	11,8	13,0	
	0,55		3,8	4,9	5,8	8,3	10,5	11,8	13,6				
	0,75*		5,1	6,6	8,2								
	1,10*		7,7										

* Not IEC-standard,

Motor		Series 52									
		η start [%]	18	17	16	15	12	10	9	8	
		Gear ratio	7,5:1	10:1	15:1	19:1	30:1	38:1	51:1	62:1	
[rpm]	[kW]	v [mm/min]	560	420	280	221	140	111	82	68	
		maximum pull/thrust load with spindle TR 30x6 [kN]									
700	0,12		2,8	3,5	4,6	5,7	7,2	7,4	8,7	8,9	
	0,18		4,2	5,5	7,6	9,0	11,7	12,2	13,6	13,9	
	0,25		6,5	8,2	10,7	13,0	16,4	17,2	19,3	19,6	
	0,37		9,7	12,1	16,1	19,5	24,8	26,0	29,0	29,4	
	0,55		14,7	18,5							
[rpm]	[kW]	v [mm/min]	720	540	360	284	180	142	106	87	
		maximum pull/thrust load with spindle TR 30x6 [kN]									
900	0,18		3,3	4,1	5,9	6,8	8,7	9,2	10,9	11,9	
	0,25		5,0	6,3	8,5	10,1	13,0	13,8	15,6	16,9	
	0,37		7,7	9,7	13,6	15,2	19,8	20,7	23,7	25,5	
	0,55		12,0	14,7	20,3						
	0,75		16,5								
[rpm]	[kW]	v [mm/min]	1,120	840	560	442	280	221	165	135	
		maximum pull/thrust load with spindle TR 30x6 [kN]									
1400	0,25		3,1	4,0	5,2	6,5	8,3	8,9	10,1	11,1	
	0,37		4,7	6,2	8,2	10,2	13,3	14,2	16,3	16,7	
	0,55		7,4	9,4	12,5	15,5	20,1	21,4	24,6	25,3	
	0,75		10,3	12,8	17,2						
[rpm]	[kW]	v [mm/min]	2,240	1,680	1,120	884	560	442	329	271	
		maximum pull/thrust load with spindle TR 30x6 [kN]									
2800	0,37		2,4	3,1	4,3	5,4	7,0	8,1	9,5	11,0	
	0,55		3,6	4,8	6,9	8,1	11,8	12,3	14,5	16,6	
	0,75		5,3	6,8	9,4	11,5	16,3	17,2	20,3		
	1,10		8,2	10,0	14,1						
	1,50		11,3								

Tables of effects

For worm gear screw jacks with through-going spindle, ED 20 %

Motor		Series 61								
		η start [%]	15	14	12	10	8	7	6	5
		Gear ratio	7:1	10:1	15:1	21:1	30:1	40:1	48:1	60:1
[rpm]	[kW]	v [mm/min]	700	490	327	233	163	123	102	82
maximum pull/thrust load with spindle TR 40x7 [kN]										
700	0,18		3,1	4,6	5,8	6,9	8,8	10,0	10,9	11,9
	0,25		4,6	6,5	8,4	9,8	12,6	14,7	15,3	16,8
	0,37		7,0	9,9	13,0	14,8	19,9	24,2	24,4	25,4
	0,55		13,3	15,0	19,7	22,1	30,0	36,5	36,6	38,3
	0,75		18,4	20,5	27,1	30,4				
[rpm]	[kW]	v [mm/min]	900	630	420	300	210	158	131	105
maximum pull/thrust load with spindle TR 40x7 [kN]										
900	0,25		3,6	5,0	6,7	8,0	10,2	11,4	12,2	13,6
	0,37		5,5	8,0	10,0	12,4	16,3	18,2	20,5	21,5
	0,55		8,5	12,0	16,1	18,9	24,5	27,5	30,9	32,4
	0,75		11,8	17,1	22,1	26,0				
	1,10		17,5							
[rpm]	[kW]	v [mm/min]	1,400	980	653	467	327	245	204	163
maximum pull/thrust load with spindle TR 40x7 [kN]										
1400	0,25		2,3	3,1	4,4	5,1	6,5	7,7	8,4	9,0
	0,37		3,5	4,8	6,7	8,1	10,5	12,2	13,5	14,3
	0,55		5,5	7,7	10,5	12,2	15,8	18,5	20,5	21,9
	0,75		7,8	10,5	15,0	17,0	21,8	25,4	28,4	29,9
	1,10		11,7	15,8	22,0	25,1				
	1,50		16,1							
[rpm]	[kW]	v [mm/min]	2,800	1,960	1,307	933	653	490	408	327
maximum pull/thrust load with spindle TR 40x7 [kN]										
2800	0,37		1,8	2,5	3,2	4,0	5,6	6,8	7,6	8,1
	0,55		2,8	3,9	5,5	6,5	8,7	10,5	11,7	12,8
	0,75		3,9	5,4	7,5	9,1	12,8	14,6	16,5	17,9
	1,10		5,7	8,3	11,3	13,5	19,1	21,9	24,5	
	1,50		8,0	11,4	15,8	18,9				
	2,20		11,9	16,9						

Motor		Series 79								
		η start [%]	14	13	11	10	8	7	6	5
		Gear ratio	7,3:1	10:1	15:1	21:1	30:1	42:1	50:1	62:1
[rpm]	[kW]	v [mm/min]	668	490	327	233	163	117	98	79
maximum pull/thrust load with spindle TR 40x7 [kN]										
700	0,37		7,6	10,1	14,5	19,0	25,0	33,6	35,6	38,8
	0,55		11,4	15,0	21,5	28,3	37,3			
	0,75		15,5	20,5	30,0	38,6				
	1,10		22,8							
[rpm]	[kW]	v [mm/min]	859	630	420	300	210	150	126	102
maximum pull/thrust load with spindle TR 40x7 [kN]										
900	0,55		6,5	8,8	11,4	14,4	19,0	24,8	27,8	32,7
	0,75		13,0	14,4	17,0	21,4	28,3	36,9	41,2	
	1,10		19,1	21,5	23,1	29,2	38,5			
	1,50		26,1	29,6	33,9					
	0,75		16,5							
[rpm]	[kW]	v [mm/min]	1,337	980	653	467	327	233	196	158
maximum pull/thrust load with spindle TR 40x7 [kN]										
1400	0,75		8,7	11,6	16,2	20,0	26,1	32,4	36,4	43,0
	1,10		12,7	17,0	23,7	29,4				
	1,50		17,4	23,1						
[rpm]	[kW]	v [mm/min]	2,674	1,960	1,307	933	653	467	392	316
maximum pull/thrust load with spindle TR 40x7 [kN]										
2800	1,10		6,3	8,6	11,7	15,3	20,2	25,1	27,9	32,2
	1,50		8,7	11,7	16,0	20,8	27,5			
	2,20		12,7	17,2	23,5					
	3,00		17,4							

The values apply to well run in and conditioned gearboxes as well as clean and well-lubricated spindles.
η Start = starting efficiency in %.

Higher speed can be achieved by using a ball screw spindle - please contact BJ-Gear. If you are using rotating spindle please contact our Sales Department for maximum load.

Make sure your motor start up power is sufficient. See calculation example on page 16.

Static load

The table shows the maximum static load the worm gear screw jack can withstand when using a safety factor of 2. For this to apply, the mounting rules indicated at page 10 must be respected.

Series	42	52	61	79
Spindle size	TR 24x5	TR 30x6	TR 40x7	TR 40x7
Maximum static load [kN]	20	33	55	58





Safety factor against breakage = 2.

Mounting of gearbox

2 52 1 0 72 2 13 03 01 40 0 0

There are different opportunities for types of housing. "1" indicates a type 1 housing with no support. The second digit is defined by the choice between a bearing cover or a side flange.

The side flange can be manufactured to fit directly into the machine where it is to be used. By doing so, you can often save both space and money.

Type 1 housing. No support	Type 2 housing. With support and worm at top	Type 3 housing. With support and worm at bottom	Type 4 housing. Stainless steel
			
1	2	3	4

Be aware that the threads in the base cannot be used as fixing point as the fixing point has to be perpendicular to the working direction of the spindle.

With bearing cover	With side flange
	
0	1

In order to prevent the thread in the gear housing from breaking off or the side flange and the gear housing from moving apart, make sure your way of mounting is as illustration 1 or 3. If you are in need of mounting as illustrated in illustration 2 and 4, please consult with BJ-Gear's specialists since maximum permissible load needs to be reduced. Also, make sure that the fixing

surface of the worm gear screw jack is stable and even as well as perpendicular to the working direction of the spindle. All data are based on axial forces since the worm gear screw jack must not be affected by radial forces (bending strain). The spindle must always be 100 % in mesh with the nut.

Ideal way of mounting:

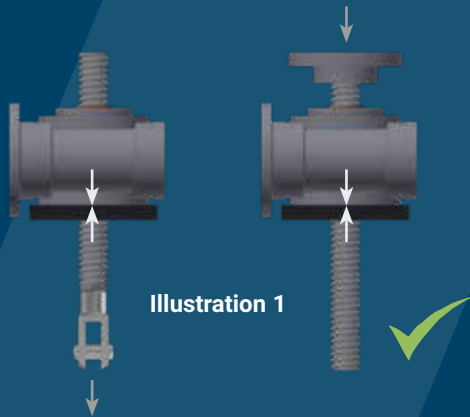

Illustration 1

Ideal way of mounting gearboxes with sideflanges:

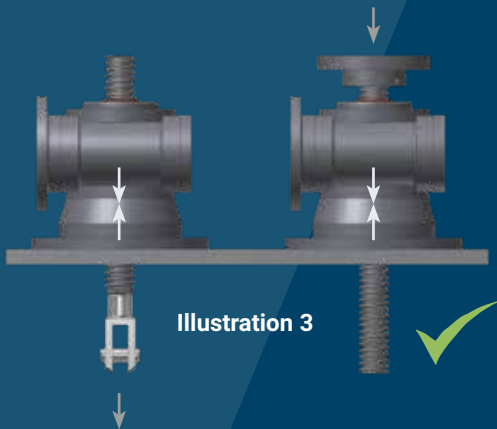

Illustration 3

Mounting is subject to reservations. Contact our specialists:

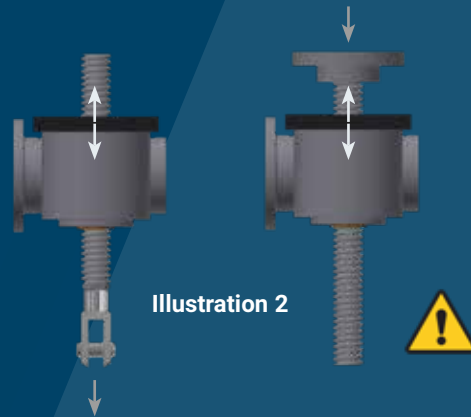

Illustration 2

Mounting of gearboxes with sideflanges is subject to reservations. Contact our specialists:

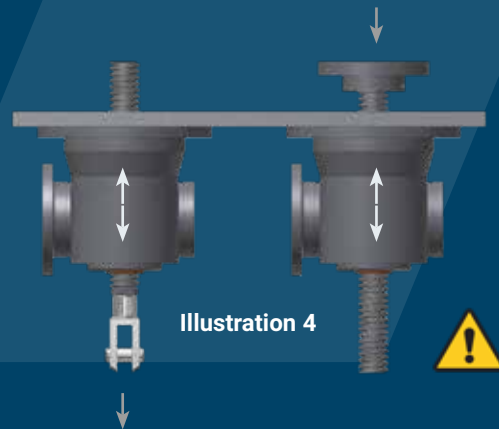



Illustration 4

Output shaft

2 52 1 0 72 2 13 03 01 40 0 0

Hollow shaft with trapezoidal screw thread for through-going spindle		
	Right	Left
Series 42, TR 24x5	61	71
Series 52, TR 30x6	62	72
Series 61, TR 40x7	63	73
Series 79, TR 40x7	63	73

Bearing at output shaft

2 52 1 0 72 2 13 03 01 40 0 0

The output shafts used in the BJ-Gear worm gear screw jacks are supported with tapered roller bearings as standard. The digit "2" indicates shafts with tapered roller bearings, if other options are required, please contact our Sales Department.

D-side

2 52 1 0 72 2 13 03 01 40 0 0

IEC norm (B14)	Motor flange [BCD]	42	52	61	79	
56	65	10	10	-	-	
63	75	11	11	11	-	
71	85	12	12	12	-	
80	100	13	13	13	13	
90	115	14	14	14	14	
100/112	130	15	15	15	15	
132	165	-	16	16	16	
160	215	-	-	-	17	
	OMM	18	18	18	-	
	OMR/OMP	-	-	19	19	

IEC norm (B14)	Coupling house [BCD]	42	52	61	79	
71	85	42	-	-	-	
80	100	43	43	43	43	
90	115	-	44	44	44	

Open end cover		42	52	61	79	
-	-	30	30	30	30	

Inputshaft

2 52 1 0 72 2 13 03 01 40 0 0

	Series 42	Series 52	Series 61	Series 79	
Hollow input shaft					
Ø11	01	-	-	-	
Ø14	02	02	02	-	
Ø19	-	03	03	03	
Ø24	-	04	04	04	
Ø28	-	-	-	05	
Hollow input shaft and free shaft on ND-side					
Ø9	-	-	-	-	
Ø11	21	-	-	-	
Ø14	22	22	22	-	
Ø19	-	23	23	23	
Ø24	-	24	24	24	
Ø28	-	-	-	25	
Free input shaft					
Ø15x40 mm	40	-	-	-	
Ø19x42 mm	-	40	-	-	
Ø19x40 mm	-	-	40	-	
Ø24x60 mm	-	-	-	40	
Free input shaft and free shaft on ND-side					
Ø15x40 mm + Ø15x38 mm	50	-	-	-	
Ø19x42 mm + Ø19x40 mm	-	50	-	-	
Ø19x40 mm + Ø19x40 mm	-	-	50	-	
Ø24x60 mm + Ø24x60 mm	-	-	-	50	

ND side (Non Drive)

2 52 1 0 72 2 13 03 01 40 0 0

If you are in need of a cover for brake, flange for encoder or other special designs please contact our Sales Department.

01	30
Closed end cover	Open end cover for free shaft on ND-side

Gearing

2 52 1 0 72 2 13 03 01 40 0 0

The gearing is defined by your selection in the tables of effect. The gearing is not the only factor defining the linear speed. The linear speed is a calculation of the gear ratio, the motor speed and the spindle pitch.

Below is an example how the linear speed is calculated:

$$V_{\text{Speed}} = \frac{n_{\text{motor}} \times p_{\text{spindle pitch}}}{i_{\text{gear}}}$$

V = Linear speed (mm/min).
p = The spindle pitch (mm).
n = The motor rotation speed (rpm).
i = The gearing.

Ratio code	42	52	61	79
	Gear ratio [i]	Gear ratio [i]	Gear ratio [i]	Gear ratio [i]
05	5,4:1	-	-	-
07	7,5:1	7,5:1	7:1	7,33:1
10	10:1	10:1	10:1	10:1
15	15:1	15:1	15:1	15:1
20	20:1	19:1	21:1	21:1
25	25:1	-	-	-
30	30:1	30:1	30:1	30:1
40	40:1	38:1	40:1	42:1
50	50:1	51:1	48:1	50:1
60	62:1	62:1	60:1	62:1
75	75:1	-	-	-

Gear size	Spindle	Pitch (mm)
42	TR 24x5	5
52	TR 30x6	6
61	TR 40x7	7
79	TR 40x7	7

Oil and lubricants

2 52 1 0 72 2 13 03 01 40 0 0

		Application	Viscosity ISO VG	Oil
0	Fully synthetic gear oil, standard	Normal load and ambient temp. -25 °C to +40 °C	220	Klübersynth GH 6 - 220
1	Fully synthetic gear oil	Heavy load and ambient temp. -20 °C to > +40 °C	460	Klübersynth GH 6 - 460
2	Fully synthetic gear oil	Heavy load and ambient temp. -20 °C to > +40 °C	680	Klübersynth GH 6 - 680
3	Liquid grease	Normal load and ambient temp. -40 °C to > +40 °C	1200	Klübersynth GE 46 - 1200
4	Special lubricating oil for food and pharmaceutical industries	Normal load and ambient temp. -20 °C to +40 °C	460	Klübersynth UH1 6 - 460

The specified ambient temperatures are for guidance only.
Do not mix synthetic oil with mineral oil. All data is based on synthetic oil.

Quantities of oil and lubricants

Series 42	Series 52	Series 61	Series 79
0,06 litres	0,18 litres	0,21 litres	0,5 litres

Finish

2 52 1 0 72 2 13 03 01 40 0 0

0	Coated black, standard	RAL 9005
1	No treatment	
2	Primed	
3	Corrosion resistant surface treatment	Chromated
4	Customer specified	

Accessories

- position of terminal box when adding a motor

If a motor is to be mounted onto the worm gear screw jack, it is essential to consider the position of the terminal box. The terminal box can be placed in different positions: 0°, 90°, 180° or 270°.

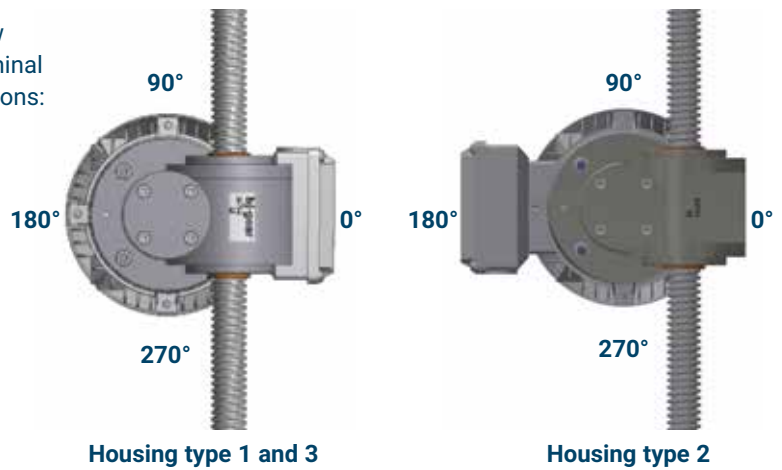

Maximum permissible axial load of trapezoidal spindle (buckling load)

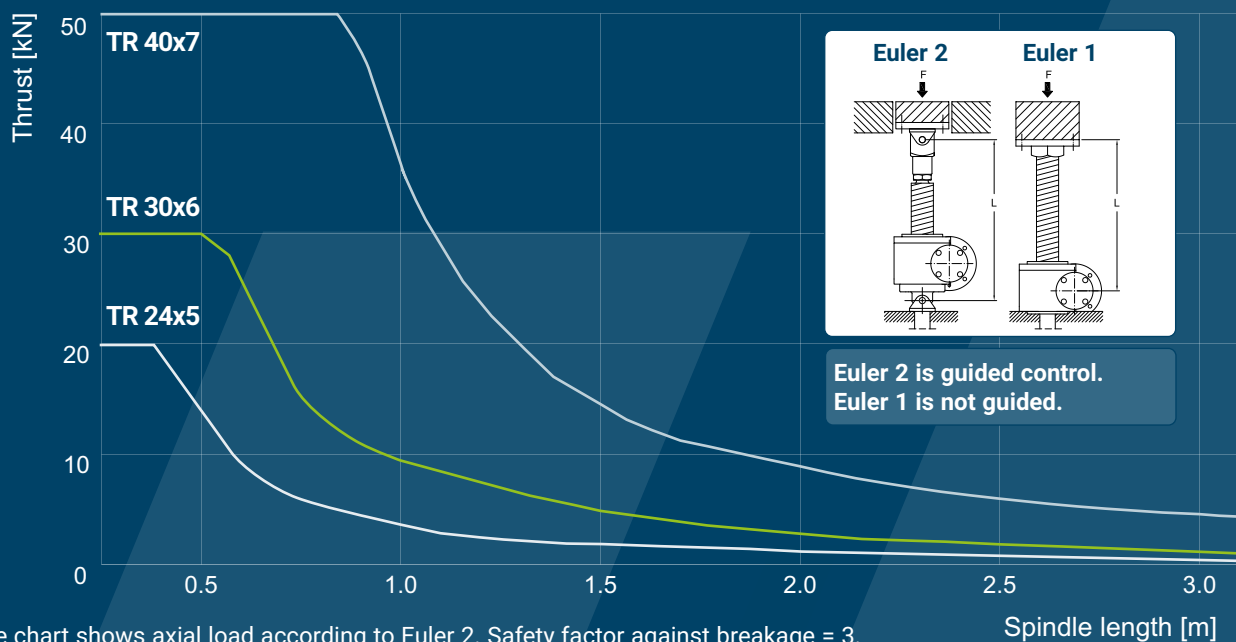

The chart shows axial load according to Euler 2. Safety factor against breakage = 3. If using axial load according to Euler 1 the selected result (maximum thrust) must be divided with 4. Guideline values apply to spindles made of steel as well as spindles made of stainless steel.

Running-in and maintenance

Running-in

The lifetime of the gearbox is increased by careful running-in. The first running time should not exceed 30 minutes, and it is necessary to make time for cooling before the next start. When doing the first running-in, it is important to take the duty factor into consideration. The load of the gearbox is gradually increased from half to full output torque.

Maintenance of spindles

A certain time for running-in must be expected. It is recommended to protect the spindle with e.g a bellow (see illustration). Due to the generation of heat between spindle and nut, the gearboxes should not work continuously with heavy load. Also, it is important that spindles and nuts are kept clean and well-lubricated by using a quality spindle grease. All data are based on clean and well-lubricated spindles. With daily operations the spindle should be checked weekly and lubricated as required. With fewer running hours, monthly checks are sufficient.

Spindle protection

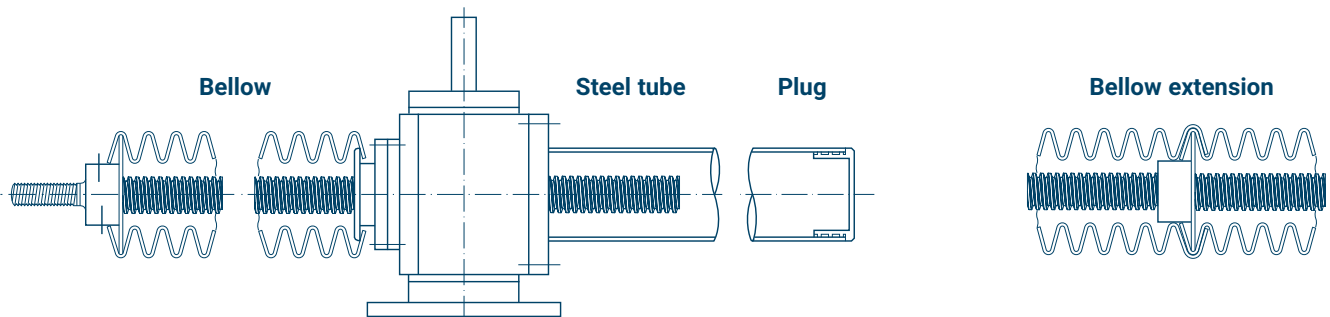

Spindle specification, rolled acme thread

Type	Material	Material condition	Tolerance diameter	Tolerance pitch	Tolerance straightness
Precision	Steel: C45 EN0503	stress-free	e7	0,1/300 mm	0,2/300 mm
Precision	Stainless steel: EN4401	stress-free	e7	0,2/300 mm	0,06/300 mm

Spindles are stocked in lengths of 3 metres to be shortened and machined on request,

Maintenance of the gearboxes

The gearboxes are lifetime lubricated and require no special maintenance. However, for gearboxes with heavy load, the oil should be changed approximately every five years. Gearboxes working in very warm environments may require oil change once a year.

NOTE: All data stated are based on synthetic oil. Synthetic oil should not be mixed with mineral oil.

Gearbox number

To ensure continuous identification, the gearboxes are marked with a unique gearbox number on the ND-side. The unique number consists of a serial number and the gearing ratio. Stating the gearbox number, we can quickly supply a replacement gearbox.

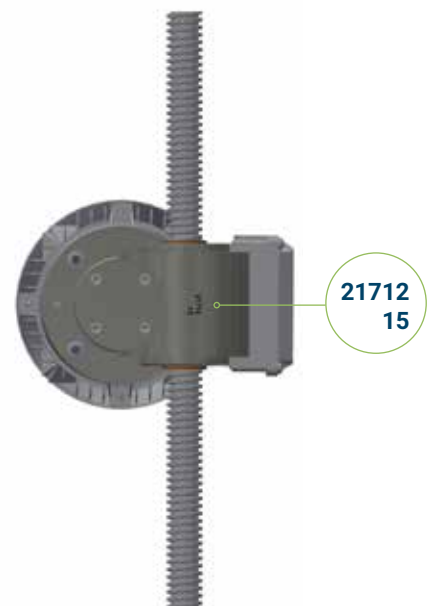

Formulas

ED example

If an ED factor higher than 20 % is required, a new calculation must be made.

Example: a load of 9 kN is to be lifted.

F_{run} is the total load in kN.

F_{max} = Maximum pull/ thrust for the chosen gear ratio.

ED 30 % is required = factor 0.7

Following formula is used:

$$F_{max} * ED \text{ factor} = F_{run} \Rightarrow 14.4 * 0.7 \text{ [kN]} = 10$$

Maximum permissible load on ED 30 % is 10 kN.

In this case the actual force is 9.0 kN, which is less than the permissible load 10 kN, and therefore acceptable.

Motor		Series 42					
		maximum pull/thrust load with spindle TR 24x5 [kN]					
		η start [%]	17	15	13	12	10
		Gear ratio	10:1	15:1	20:1	25:1	30:1
[rpm]	[kW]	v [mm/min]	700	467	350	280	233
1,400	0,09		1,6	2,0	2,6	3,1	3,3
	0,12		2,3	2,9	3,6	4,4	4,7
	0,18		3,5	4,2	5,6	6,6	7,2
	0,25		4,7	6,2	7,8	9,4	10,4
	0,37		7,3	9,5	12,0	14,4	15,7
	0,55*		11,3	14,3			

Starting power

It is essential that the motor is dimensioned to handle the power required for start-up. This applies especially when using other driving units than three-phased AC motors e.g air motors and hydraulic motors. Then the power has to be recalculated. 3-phased AC motors normally have a starting power of 2-2.5 times the normal output torque, making the motor able to overcome the starting efficiency without any problems.

Calculation of the starting power:

$$P_{start} = \frac{F_{run} \times V_{run}}{\eta_{start} \times 60 \times 1000} \text{ [kW]}$$

- P_{start} = Starting power drive motor [kW]
- F_{run} = Total load in [kN]
- V_{run} = Lifting speed (linear speed) in [mm/min]
- η_{start} = Starting efficiency [%]

Example of calculation

A load of 9 kN is to be lifted at a speed of approx. 300 mm/min. A solution with series 42, TR 24x5 with a 1400 rpm motor 0.25 kW and gear ratio 25:1 is chosen. It can lift/pull 9.4 kN at a lifting speed of 280 mm/min. Starting efficiency is 12 %.

Motor		Series 42											
		maximum pull/thrust load with spindle TR 24x5 [kN]											
		η start [%]	19	18	17	15	13	12	10	8	7	6	5
		Gear Ratio	5,4:1	7,5:1	10:1	15:1	20:1	25:1	30:1	40:1	50:1	62:1	75:1
[rpm]	[kW]	v [mm/min]	1296	933	700	467	350	280	233	175	140	113	93
1400	0,09				1,6	2,0	2,6	3,1	3,3	4,0	4,3	4,7	5,3
	0,12		1,4	1,8	2,3	2,9	3,6	4,4	4,7	5,2	6,1	6,6	7,4
	0,18		2,3	2,9	3,5	4,2	5,6	6,6	7,2	8,1	9,5	10,2	11,3
	0,25		3,2	4,0	4,7	6,2	7,8	9,4	10,4	11,6	13,6	14,6	
	0,37		4,6	6,0	7,3	9,5	12,0	14,4	15,7	17,1	19,9		
	0,55*		7,0	9,2	11,3	14,3							
0,75*		9,9											

The table values are operating figures. In order to check whether the motor is strong enough to cope with the starting power by lifting or pulling, the following formula for starting power may be used:

$$P_{start} = \frac{9 \times 280}{0,12 \times 60 \times 1000} \quad P_{start} = 0,35 \text{ [kW]}$$

In this calculation the motor will be strong enough, since an ordinary standard-dimensioned motor in a short time (starting torque) can perform up to approx. 2-2.5 times its nominal torque. For extra safety you can choose a larger motor such as 0.37 kW.

Dimensional drawings for high shape

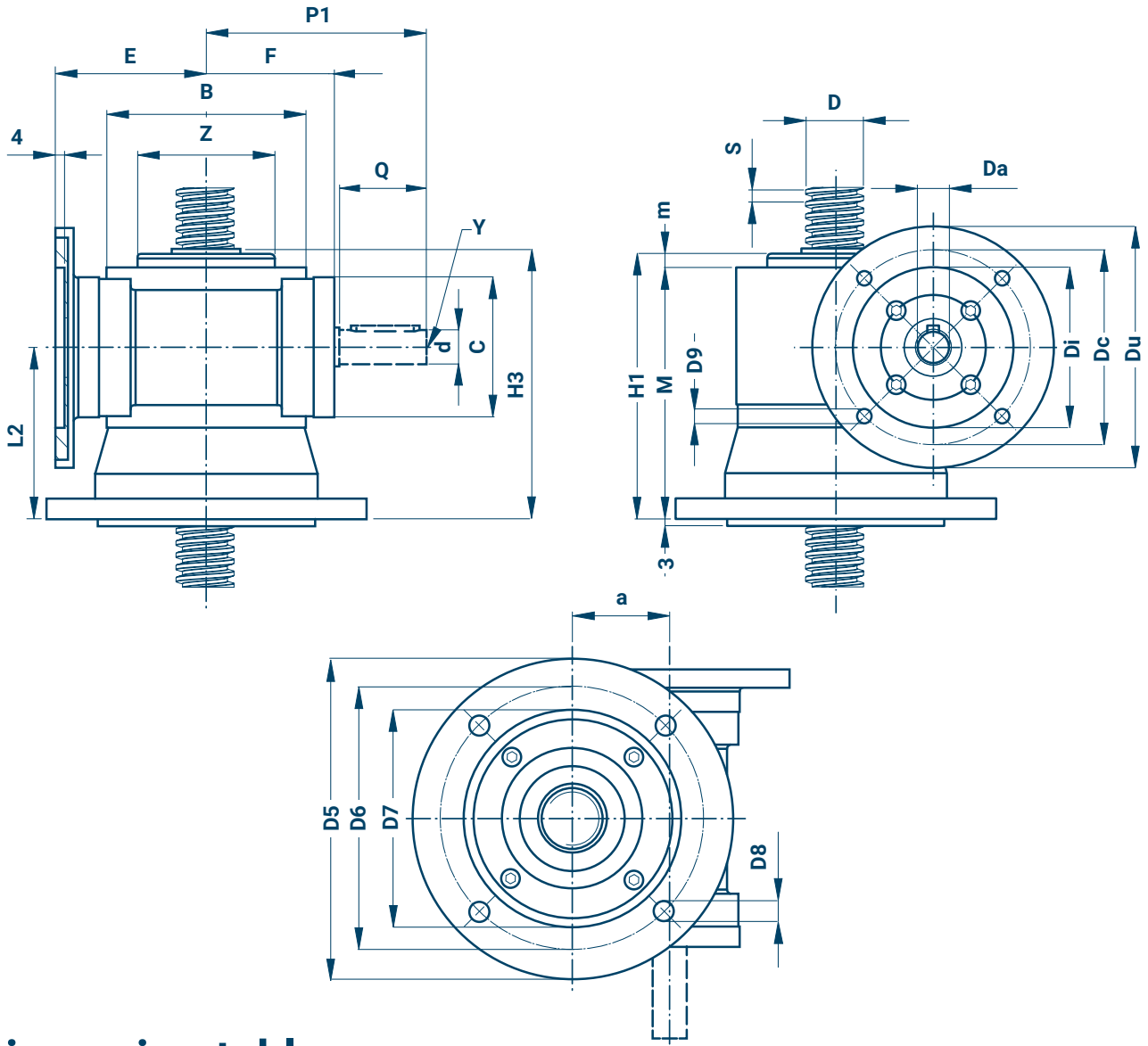

Dimension tables

Gear series	Spindle		Main dimensions										Worm shaft				Attachment				Weight kg
	D	S	a	B	C	F	H1	H3	L2	M	m	Z ^{h7}	P1	d ^{k6}	Q	Y	D5	D6	D7 ^{h7}	D8	
42	24	5	42,5	87	60	56	116	118	75	110	6	60	96	15	38	M6x14	140	115	95	9	5,4
52	30	6	52,5	110	72	68	126	128	80	120	6	65	110	19	40	M8x15	140	115	95	9	9
61	40	7	61,0	126	72	82	132	140	85	127	5	90	123	19	40	M8x15	200	165	130	11	12
79	40	7	79,0	164	82	97	153	157	100	146	7	105	159	24	60	M8x15	200	165	130	11	23

Gear series	Frame size IEC 71 - B14						Frame size IEC 80 - B14						Frame size IEC 90 - B14						
	Da ^{G7}	Dc	Di ^{F6}	Du	D9	E	Da ^{G7}	Dc	Di ^{F6}	Du	D9	E	Da ^{G7}	Dc	Di ^{F6}	Du	D9	E	
42	14	85	70	105	7	66													
52	14	85	70	105	7	82	19	100	80	120	7	82	24	115	95	140	9	92	
61	14	85	70	105	7	91	19	100	80	120	7	91	24	115	95	140	9	101	
79							19	100	80	120	7	118	24	115	95	140	9	118	

Gear series	Frame size IEC 100 and IEC 112-B14					
	Da ^{G7}	Dc	Di ^{F6}	Du	D9	E
79	28	130	110	160	9	126

Key and keyway according to DIN 6885

Dimensional drawings for low shape

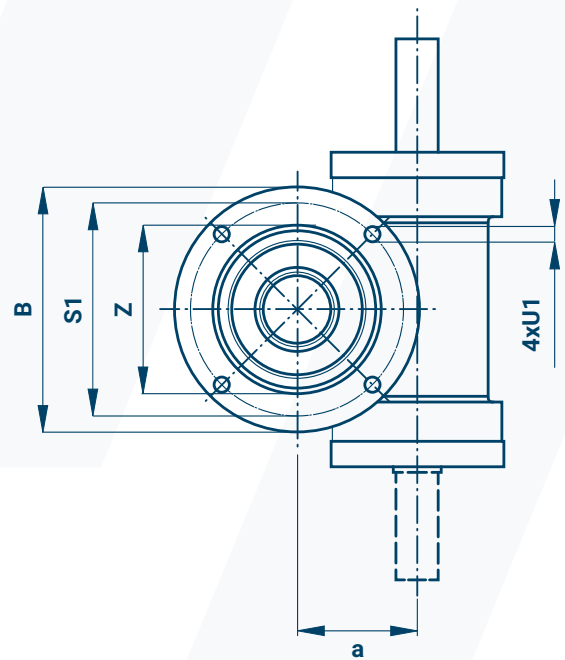
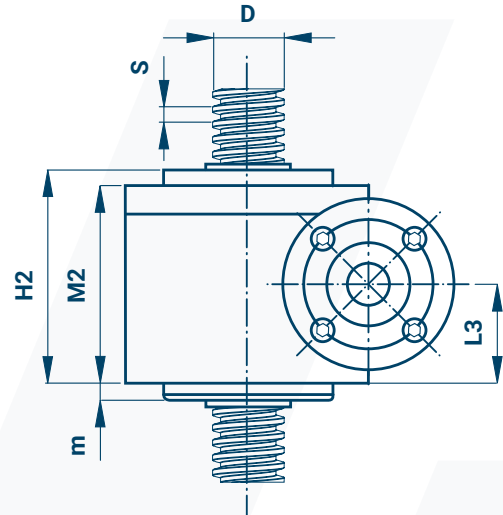
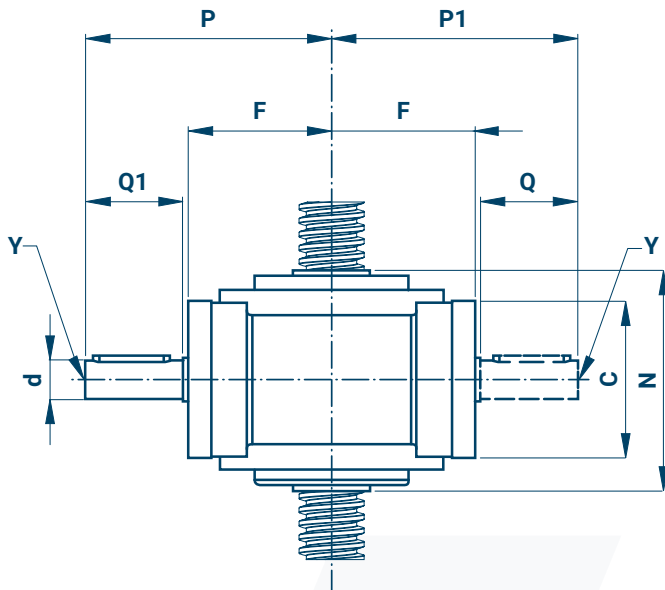

Weight of spindles

Spindle	Weight in kg per meter	
	Steel	Stainless steel
TR 24x5	2,7	2,7
TR 30x6	4,4	4,4
TR 40x7	8,0	8,0

Dimension table

Gear series	Spindle		Main dimensions								Worm shaft						Attachment				Weight kg
	D	S	a	C	F	H2	L3	M2	m	N	P	P1	d ^{k6}	Q	Q1	Y	Z	S1	B	U1	
42	24	5	42.5	61	56	76	35	70	6	86	96	96	15	40	38	M6x14	60	76	87	M6x9	4.5
52	30	6	52.5	72	68	86	40	80	6	96	110	110	19	42	40	M8x15	65	95	110	M6x9	8
61	40	7	61.0	72	82	89	42	83	5	110	120	123	19	40	40	M8x15	90	108	126	M8x12	10
79	40	7	79.0	82	97	99	46	92	7	110	159	159	24	60	60	M8x15	105	125	164	M10x12	18

Key and keyway according to DIN 6885

Dimensional drawings for spindle connections

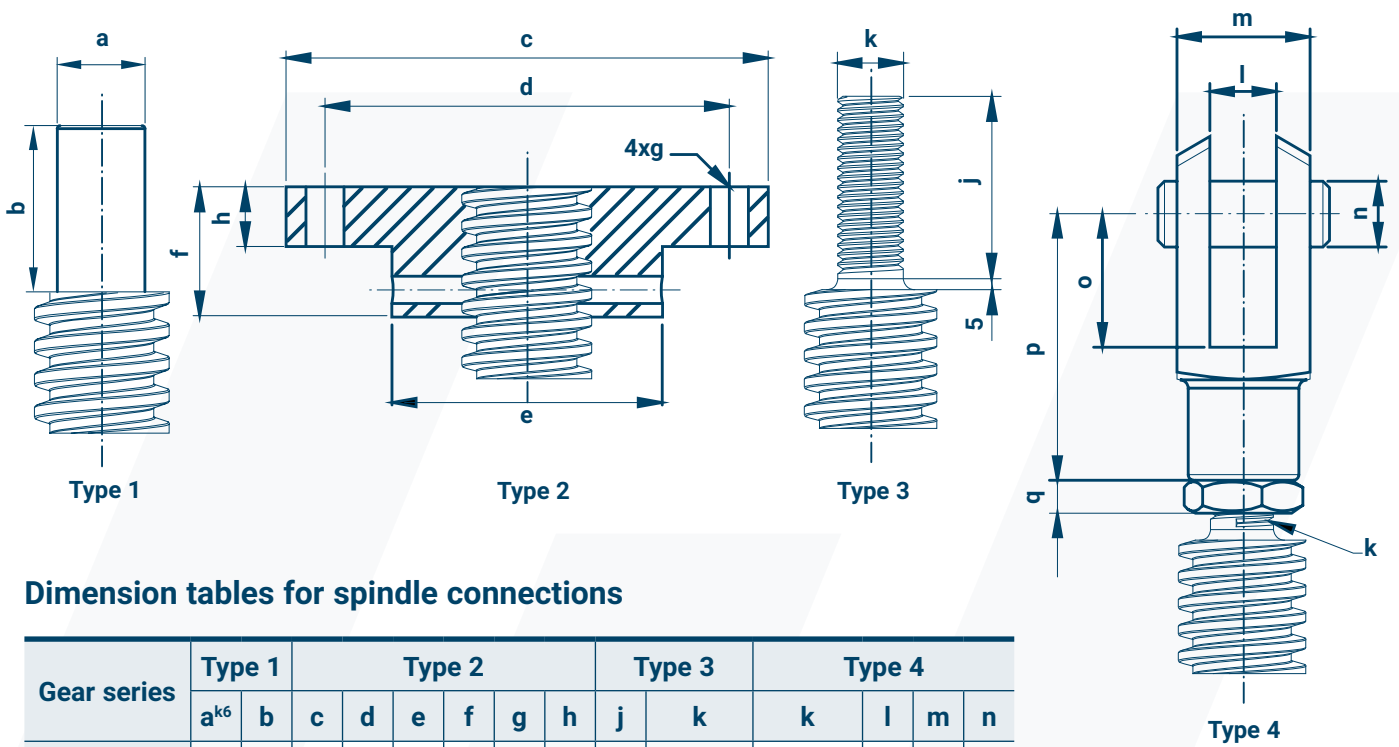

Dimension tables for spindle connections

Gear series	Type 1		Type 2						Type 3		Type 4			
	a ^{k6}	b	c	d	e	f	g	h	j	k	k	l	m	n
42	16	30	89	75	50	24	7	11	34	M16x1.5	M16x1.5	16	32	16
52	18	30	105	85	55	30	7	11	43	M20x1.5	M20x1.5	20	40	20
61	24	40	118	100	65	40	9	16	50	M24x2	M24x2	25	50	25
79	24	40	118	100	65	40	9	16	65	M30x2	M30x2	30	60	30

Gear series	Type 4			Type 5						
	o	P	q	k	q	r ^{H6}	t	u	v	
42	32	64	8	M16x2	8	16	21	64	21	
52	40	80	10	M20x1.5	10	20	25	77	25	
61	50	100	12	M24x2	12	25	31	94	31	
79	60	120	15	M30x2	15	30	36	110	37	

Maximum load connections [kN]

Gear series	Type 1 *)	Type 2 **)	Type 3	Type 4	Type 5
	Pull/Thrust	Pull/Thrust	Pull/Thrust	Pull/Thrust	Pull/Thrust
42	*)	20	18,3	18,3	16
52	*)	30	29	29	23
61	*)	39	31	31	26
79	*)	43	48,4	48,4	48,4

* Machined end for support bearing, ** Standard in stainless steel,

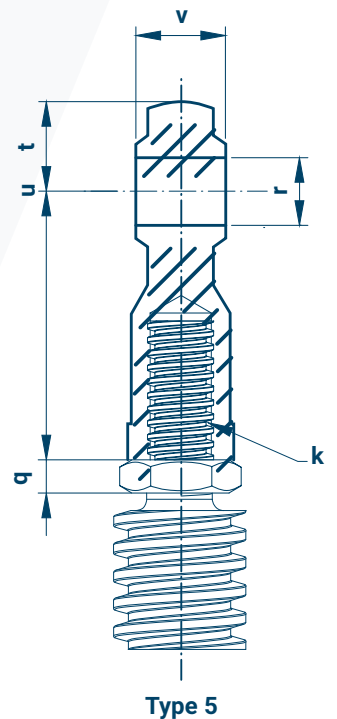

Line shafts (connecting shafts)

Line shafts (connecting shafts) are used for synchronous operation of the worm gear screw jack. Series 10 - 800

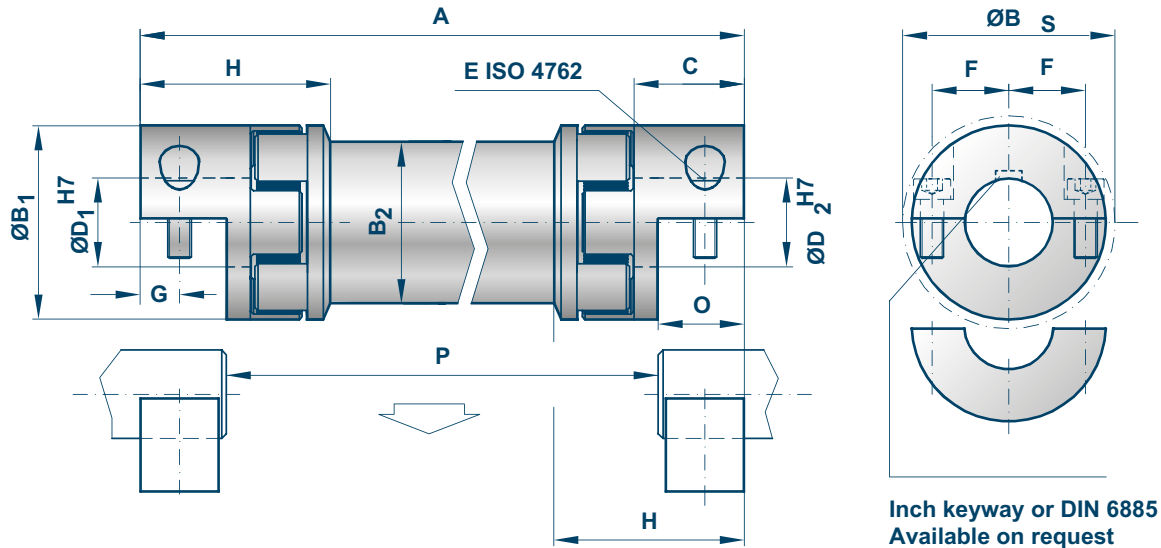
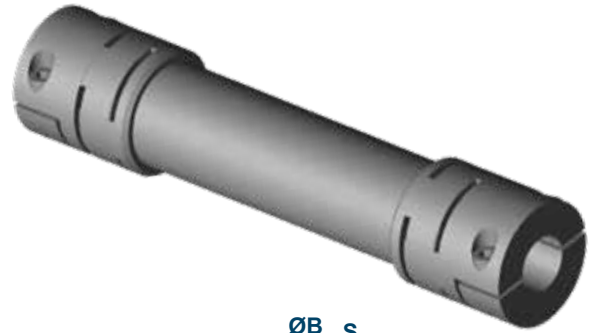

The total length of the axis is defined by the distance $P + 2 \times O$

Properties

- Lateral mounting due to split hubs
- Spans distances of up to 4 m
- Low moment of inertia
- Vibration damping
- Press fit designs
- Backlash free line shaft

Material

- Clamping hub of high strength aluminium
- Elastomer inserts are precision molded, wear resistant, and thermally stable polymer
- Precision machined aluminum intermediate tube

Design

Two split coupling hubs are concentrically machined with concave driving jaws. Both coupling bodies are rigidly mounted to tubes with high concentricity. While loosening the tube clamping, a length variation is possible within the given range. Elastomer inserts are available in type A or B.

Speed

To control the critical resonant speed, please advise the application speed when ordering or inquiring about EZ2 line shafts.

Tolerance

On the hub/shaft connection 0.01 to 0.05 mm.

Model EZ2	Type	T _{KN}	T _{Kmax}	A	B1	B2	Bs	C	D _½	E	F	G/G1	H	J ₁ /J ₂	J ₃	C _{Tdyn} ^E	C _T ^{ZWR}	N	O	
20	A	17	34	130-4000	42	35	44,5	25	8-25	4	4xM5	15,5	8,5	46	0,02	0,183	1270	1530	33	18,6
	B	21	42														2220			
60	A	60	120	175-4000	56	50	57	40	14-32	15	4xM6	21	15	63	0,5	0,66	3970	6632	49	32
	B	75	150														5950			

Selection process for servo insert couplings, EZ2

- A Overall length [mm]
- AB Length AB = (A-2xN) [mm]
- B1 Outside diameter of clamping hub [mm]
- B2 Outside diameter of tube [mm]
- Bs Outside diameter with screw head [mm]
- C Fit length [mm]
- C_{Tdyn}^E Combined dynamic torsional stiffness of the inserts [Nm/rad]
- C_{Tdyn}^{EZ} Combined dynamic torsional stiffness of the entire coupling assembly [Nm/rad]
- C_T^{ZWR} Torsional stiffness of tube per meter [Nm/rad]
- $D_{\frac{1}{2}}$ Inside diameter range H7 [mm]
- E Clamping screw [ISO 4762]
- F Distance between centers [mm]
- G/G1 Distance [mm]
- H Length of the coupling [mm]
- J_1/J_2 Moment of inertia per coupling [10^3 kgm^2]
- J_3 Inertia of tube per meter [10^3 kgm^2]
- N Distance between centers [mm]
- O Mounting length [mm]
- TK_{max} Max. torque
- Z Tube length ($Z=A-2xH$) [mm]
- φ Angle of twist [degree]

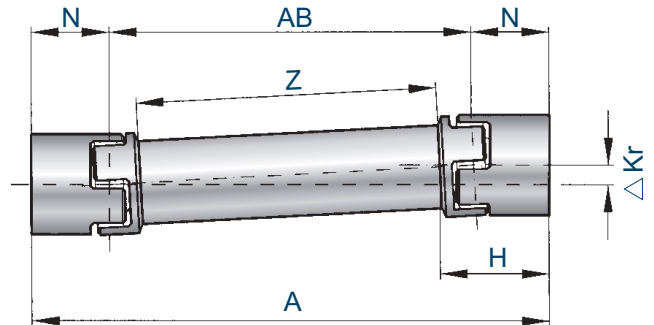

According to torsional stiffness

$$C_{Tdyn}^{EZ} = \frac{C_{Tdyn}^E \times (C_T^{ZWR}/Z)}{C_{Tdyn}^E + (C_T^{ZWR}/Z)} \quad [\text{Nm/rad}]$$

According to angle of twist

$$\varphi = \frac{180 \times TK_{max}}{\pi \times C_{Tdyn}^{EZ}} \quad [\text{degree}]$$

Max. possible misalignments

Lateral misalignment ΔKr



$$\Delta Kr_{max} = \tan \Delta \frac{Kw}{2} \cdot AB$$

$$AB = A - 2xN \text{ [mm]}$$

Angular misalignment ΔKw



$$\Delta Kw_{max} = \text{ca. } 2^\circ$$

Axial misalignment ΔKa



$$\Delta Ka_{max} = \text{ca. } \pm 2 \text{ [mm]}$$

Spare parts

- 2Gasket
- 3Screw
- 3B . . .Screw
- 4Screw
- 5Oil seal
- 7Oil seal
- 8Oil seal
- 8A . . .Oil seal
- 9Tapered roller bearing
- 11 . . .Angular contact ball bearing
- 12 . . .Ball bearing
- 13 . . .Worm wheel
- 15 . . .Spacer ring
- 17 . . .Hollow output shaft
- 17A . .Hollow output shaft
- 20 . . .Hollow worm shaft
- 20A . .Hollow worm with free shaft
- 21 . . .Free worm shaft
- 21A . .Double free worm shaft
- 22 . . .Parallel key B
- 24 . . .Parallel key A
- 25 . . .Locking ring
- 26 . . .Washer A
- 27 . . .End cover, open
- 28 . . .End cover, closed
- 29 . . .Gasket
- 30 . . .Motor flange
- 31 . . .Bearing cover
- 31A . .Side flange
- 33 . . .Screw
- 35 . . .Gear housing
- 45 . . .Lock nut
- 46 . . .Washer B
- 47 . . .Coupling housing

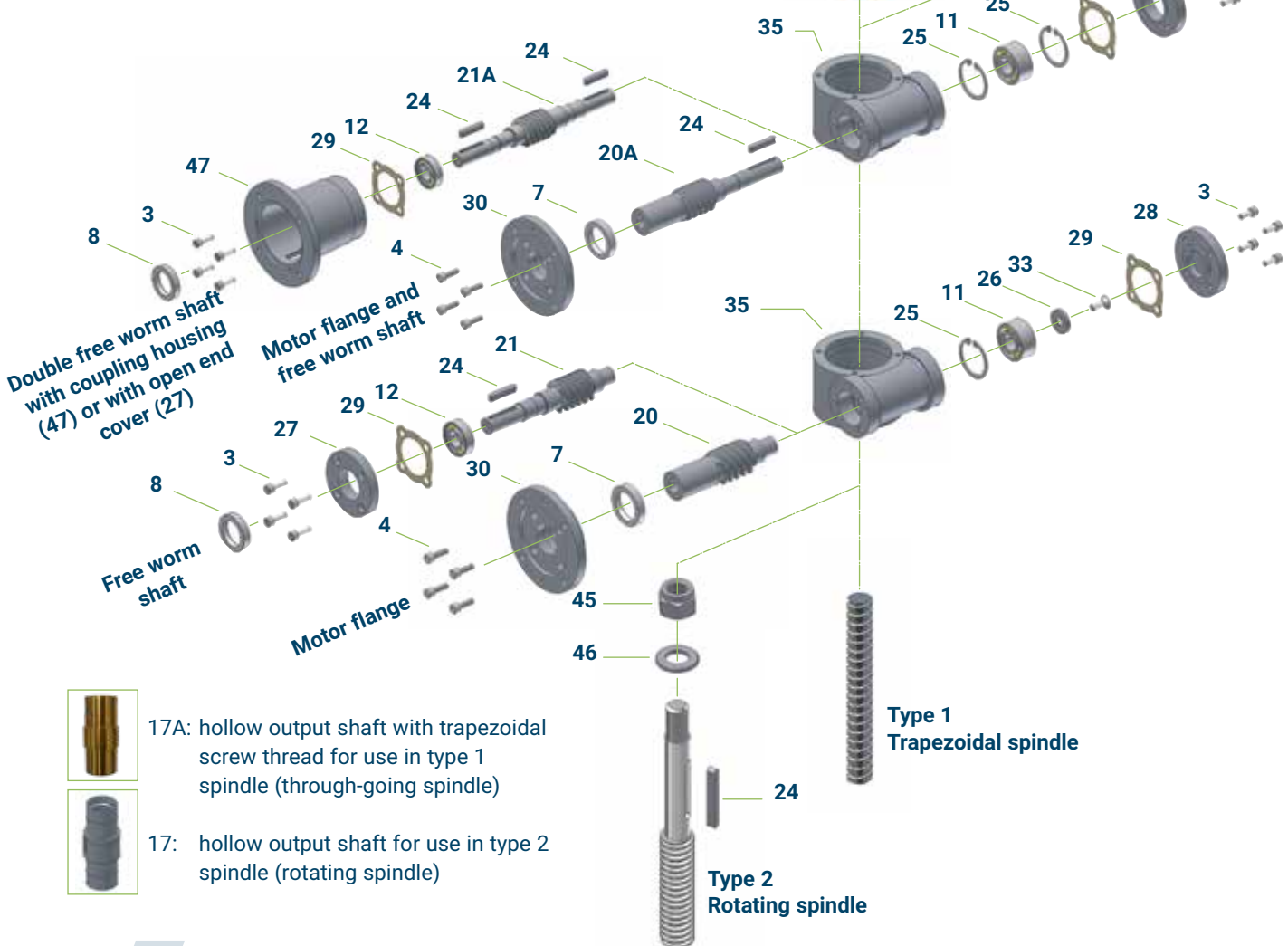

17A: hollow output shaft with trapezoidal screw thread for use in type 1 spindle (through-going spindle)



17: hollow output shaft for use in type 2 spindle (rotating spindle)

Type 1
Trapezoidal spindle

Type 2
Rotating spindle

Examples of assemblies

Synchronous movement with motor operation

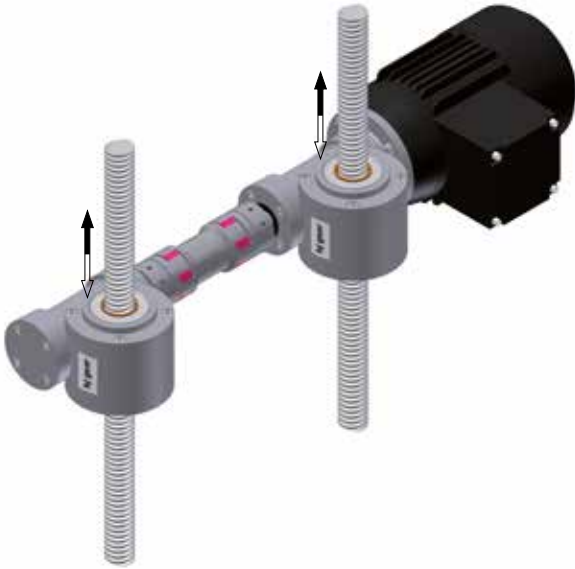

Synchronous movement in two directions with manual operation



Synchronous movement with motor operation and holding brake

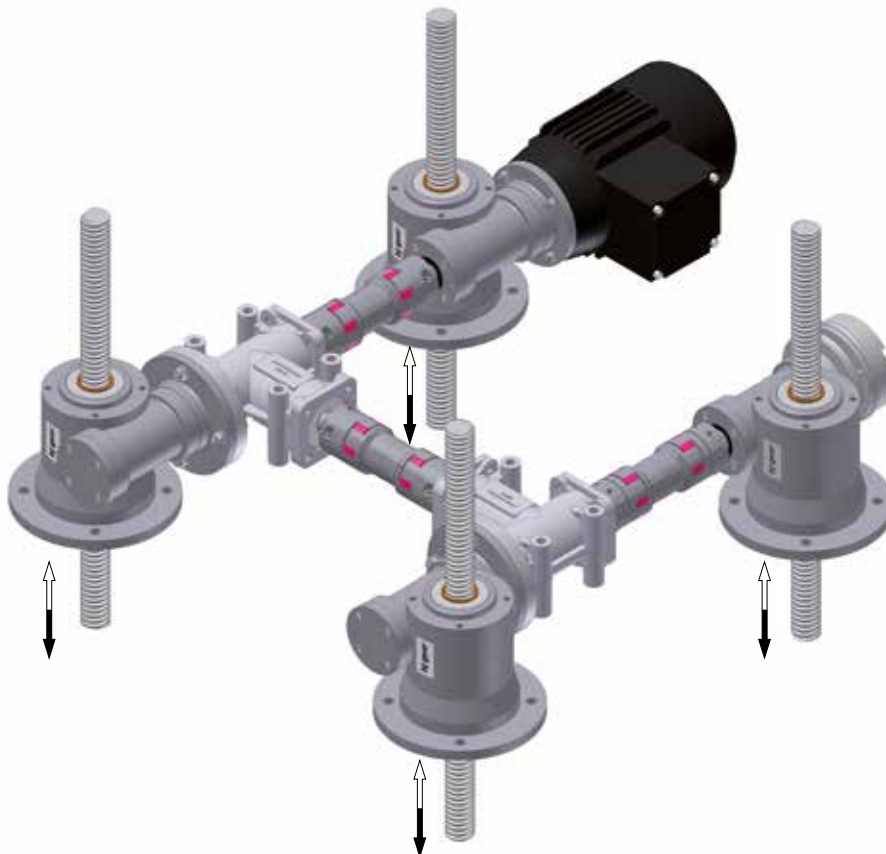

bj·gear

Customisation is our standard



BJ-Gear A/S

Niels Bohrs Vej 47
DK-8660 Skanderborg, Denmark
VAT No. DK 10166470

Phone +45 87 40 80 80
Email bj@bj-gear.com
Website www.bj-gear.com

Copyright © 2022 BJ-Gear A/S. All product rights reserved. All data, illustrations, photos, drawings and statements are for general information only and subject to change without notice and should not be considered as a warranty or legal obligation of any kind.